

**ADVANCED GCE UNIT
BUSINESS STUDIES**

Business Strategy

CASE STUDY

JANUARY 2007

2880/CS

May be opened and given to candidates upon receipt.



INSTRUCTIONS TO CANDIDATES

- This copy may **not** be taken into the examination room.
- The business described in this case study is entirely fictitious.

This document consists of **9** printed pages and **3** blank pages.

Doors, Mullions and Windows (DMW) Ltd

Selling replacement double glazing units is like selling the everlasting light bulb; once you have sold to a customer they have no reason to come back. So, to grow, Doors, Mullions and Windows (DMW) has to fight a continual battle to find new customers, and find them in an ever decreasing and competitive market place. That market is oligopolistic; a few large national firms such as Anglian and Bowater compete alongside a myriad of smaller regional firms. The presence of specialist manufacturers of window and door units means that the installation market has few barriers to entry at regional level. Indeed, some installation sales are lost to the DIY market. Sales are made direct to customers, either proactively by using sales representatives or more passively by hoping that promotional material in the media will stimulate interest in the product and, hence, a sales enquiry. A few years ago the UK replacement market was worth slightly in excess of £10bn. Public sector sales are about 10% of sales, but this proportion is falling as the size of the public sector housing stock declines. Market growth is very closely tied to housing market activity which, in turn, is heavily influenced by macro economic conditions.

5

10

Established over 60 years ago, DMW is a well respected company in Oakford and the surrounding area. Rupert Johnson, the grandson of the founder, is the Managing Director. Ownership of DMW still rests within the Johnson family, who in addition to DMW, own other businesses in the community. Mary Johnson, Rupert's sister, is titular Chairman. As representative of the other family members, she feels DMW should have 2008 objectives of 10% ROE, £2.50 EPS and returning as much cash to the shareholders as possible. Mary encourages Rupert to search out new business opportunities which will enhance DMW's profitability. One such opportunity is the possibility of buying C&G Builders.

15

20

DMW actively markets itself within about a 30km radius of the town, but typically does some business in a 50km radius through reputation (the company's record for an installation is 230km away when an existing customer moved to Cumbria). Typical of many family run businesses, DMW has evolved through market opportunities rather than deliberate strategic planning. So, for example, installing mullions has all but died as an activity, whilst the move to PVC-U windows and doors emerged as the market presented itself. Fig. 1 shows how revenue from DMW's four profit centres has changed through time.

25

DMW Sales

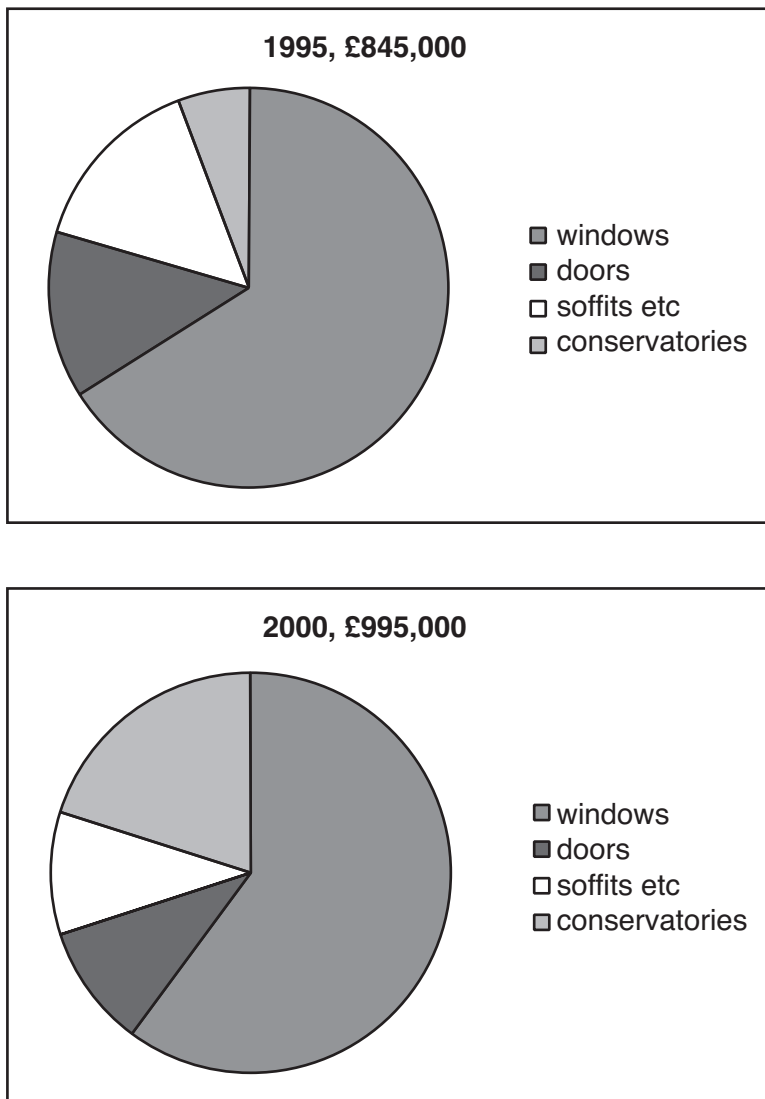

Fig. 1

30

DMW currently employs 20 people. In addition to Rupert, there are two other people in the office who deal with personnel and administration. Alison Johnson, Rupert's daughter, is in charge of Sales and as such discusses with customers the style, type and finish of product. Once this has been decided the job is passed to Minesh Patel, DMW's Senior Estimator. It is his job to cost the installation for time needed and materials. Once both Alison and Minesh have done their jobs, a contract is drawn up between the customer and DMW. If agreed, the job is then allocated to one of DMW's five installation teams. Across these teams there is a range of skills. The company aims to do all of the work in house but will, when necessary, subcontract out specialist tasks. So if, for example, a customer wants a gas fire fitting in a conservatory, DMW will hire a specialist CORGI registered fitter. Similarly, DMW's preferred roofing contractor is C&G Builders.

35

40

The need for growth is driven by the need to satisfy the business' stakeholders. In 2008 Rupert would like to see objectives of revenue rising by 5% and profits by 7.5%. To highlight how these objectives can be met, he has had the accountant analyse the performance of the business by its four main activities, see Table 1.

45

Table 1

DMW, Profit Centre Analysis, 2006				
	Windows	Doors	Soffits etc	Conservatories
Revenue	£557,256	£133,741	£111,451	£312,063
Direct costs	£391,194	£104,318	£104,318	£269,489
Indirect costs	£84,340	£21,085	£21,085	£42,170
Profit	£81,722	£8,338	(£13,952)	£404

50

This analysis has caused Rupert, Alison and Minesh to discuss the markets which DMW serves. Alison wants DMW to pull out of the replacement window market and exclusively focus on the design and installation of conservatories. She feels DMW needs to adapt to the realities of the changed market conditions. Hence, she feel it should focus on those markets where there is growth, little competition and opportunities to add value. Currently, there is no specialist conservatory business in the locality, so customers either turn to a general builder or to a national specialist. She believes DMW should exploit its two biggest intangible assets; its market reputation and the skills of its staff. Her analysis of sales enquiries shows that the two display conservatories it has recently built at a local garden centre are generating rising volumes of enquiries. The licensed trade is another big market for conservatories. Further, increasingly stringent health and safety legislation means costs are rising. "It's all right for the cowboys, they pay lip service to the law and hope they don't get caught. They're not even FENSA registered. We're a respectable firm so have no choice other than to comply. But the way the law is going costs are bound to increase, further harming our margins. The 2005 Working at Height Regulations are a classic example. We do what's required, not just because we believe we should but because the installation teams wouldn't allow us not to. But we're the exception. And, with the likes of Eaves & Slater out there, we can't just pass on the increase to the customer; we'd price ourselves out of the market. The only sensible thing to do is to pull out of installing guttering and soffits, and possibly windows as well." In essence, Alison wants DMW to adopt an objective of specialisation.

55

60

65

70

Minesh, in contrast, believes that, although the replacement window market is getting more and more difficult, it is about to turn. Enhanced product performance in terms of insulation, aesthetics and safety is providing customers with an incentive to trade up; to replace their old double glazing with more modern units. Although what he calls the "second time replacement" market is growing, it is still small and has yet to offset the overall market decline. Rather than abandon a market in which DMW has decades of experience, his argument is it should be more active. One possibility is to go out and win more "new build" contracts, either with housing associations or speculative builders. He is adamantly opposed to Alison's ideas, even to the extent of arguing that the loss making soffit business is worthwhile as it provides steady work. Further, DMW's core activities are complementary, a contract for one often resulting in orders for the others. Although work on soffits has low added value, and has low barriers to entry, correct installation does require skill and care. Minesh feels that, rather than abandon the replacement market, DMW should be doing the opposite and cites a contract to replace all the windows at London Road Primary School as exactly what it should be doing.

75

80

85

Already aware of Alison's views, Rupert has been doing some of his own research. A friend, Steve Preedy, who is a commercial estate agent, is confident that, because of the pressure in the town for low cost housing, DMW's site has residential appeal. Close to the station, and near the end of the high street, with planning for town houses, the site might be as much as 25% undervalued. Steve has provided Rupert with the details of two alternative industrial sites, see Table 2. 90

Table 2

Site comparison			
	Current site	Pound Road	Cherry Tree Farm
Distance to current site, km	n/a	0.5	8.2
Rent, pa	n/a	£25,000	£15,000
Lease	n/a	5 years	3 years
Overall size, m ²	500	520	650
• Offices	120	120	100
• Show room	80	100	n/a
External parking	4 bays	12 bays	18 bays

With the display site at the garden centre now bringing in orders, Rupert has been questioning the need for DMW to be based in the town. In fact, he can see many operational and financial benefits from a move. However, he has already been approached by some employees who have made it clear they want to stay where they are. Finding and retaining good quality employees is arguably Rupert's hardest task, even more so than finding customers – finding employees is easy; it is finding those with the right combination of technical skills and care which is difficult. With market reputation so important, he needs his staff to be not only good fitters but also good businessmen as well. Hence, DMW runs a quarterly "Customer Satisfaction" audit using a post installation questionnaire. The cash prize goes to the fitting team with the best score for various criteria including politeness, cleanliness, care of the customer's home, as well as technical aspects. Rupert would like to offer an annual profit sharing bonus to the staff, but to date this idea has been blocked by the other shareholders, worried about the impact it would have on their dividends. The culture within DMW is one of team work and professionalism. Because DMW does mainly replacement windows, the fitters' work tends to be varied and challenging. Together with above average wages, mutual respect and being treated honestly, varied work goes a long way to ensuring labour turnover remains manageable. 105

With a lack of agreement within management about objectives, Rupert is unsure whether DMW should bid for the London Road Primary School contract. With increased government spending, particularly on education, the local authority market is one which is not only growing but is also less price sensitive than in the past. Minesh, who has already surveyed the job, has told him that the gross margin would be 25% on a bid of £80,000. However, time is critical and DMW would only have the school's summer holiday to complete the contract. This would mean allocating three teams to the job. The summer is DMW's busiest time of the year because it is when most customers want their windows replacing. The school summer holidays are also the time when the fitting teams want their holidays, and a time when absenteeism traditionally rises as well. Both would combine to make achieving the target completion date more difficult. Rupert and Minesh have analysed the job and have created a plan which breaks it down into a series of activities (the duration, in days, of each activity being shown in Fig. 2). 120

London Road Primary School, activity breakdown

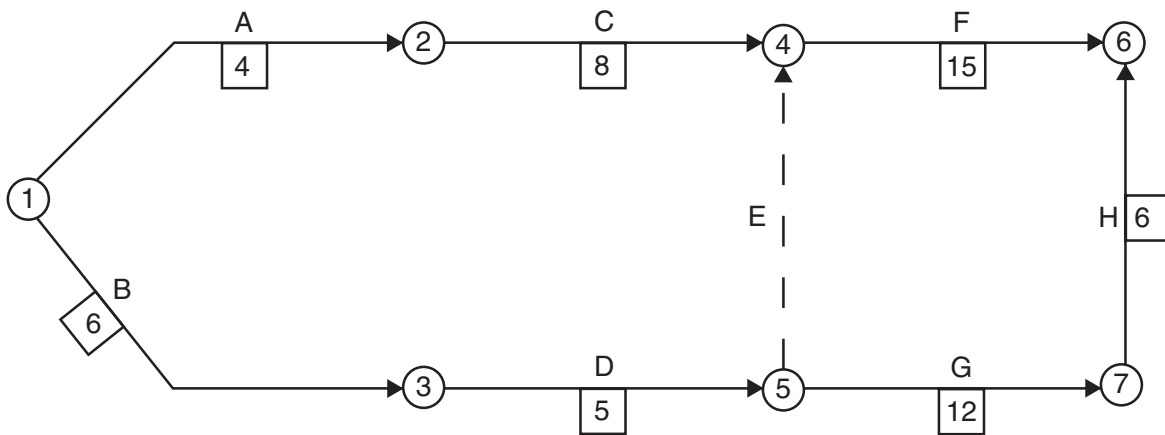

Fig. 2

If everything went well Rupert and Minesh are confident that the contract could be completed in the time available. Running over would have two consequences. First, penalty clauses in the contract would be enforced. For every day overrun a “fine” of £5,000 would be payable for the hire of temporary classroom accommodation. Second, securing additional local authority work would be nigh on impossible. Weighing all of the evidence, and Alison’s almost certain objection, Rupert is unsure of what is best.

135

Appendix 1**Building firm fined £5,000**

Local builders, Eaves & Slater, have been fined £5,000 by magistrates after day release college student, Mark Simpson, fell 30ft from a ladder. Simpson, 17, had been installing soffits and guttering to a town house on Wimbourne Way when he slipped from the wet ladder and fell, seriously injuring his back. The court was told that, despite having had two operations, Simpson still has difficulty walking unaided. In defence, Eric Jones said Eaves & Salter very much regretted the accident. He said that the firm had not been able use its Mobile Elevated Work Platform because of the damage it would have caused to the customer's lawn. Since the accident the firm has undertaken a thorough review of its operations and has had no further accidents.

The Health and Safety Executive, which brought the case, said it was pleased with the decision. Spokesman, Jim O'Kane, said, "Falls from height are the most common cause of fatality and the second most common cause of major injury to employees. They make up nearly 15% of all work related injuries. In 2004, 67 people died and nearly 4,000 suffered a serious injury as a result from falling from height. We are pleased with the court's decision as this will send a clear message to employers that they cannot ignore their responsibilities under occupational safety law."

Rosie Radford, Court Report

Source: Oakford Oracle

Appendix 2

Doors, Mullions and Windows Ltd
Internal accounts, un-audited, not for publication

Profit & Loss Account year ending 31/10/06	£	Balance Sheet as at 31/10/06	£
Sales	1,114,511	Site	400,000
Materials	445,804	Equipment (1)	166,500
Labour	423,515		566,500
Gross Profit	245,192		
		Stock	55,726
Administration	121,530	Debtors	258,628
Depreciation	41,625	Cash	13,931
			328,285
PBIT	82,037		
Interest	5,525	Trade Creditors	74,301
		Other Creditors	37,150
Taxable profit	76,512		111,451
Tax	12,395		
Net Profit	64,117	Net Current Assets	216,834
		Net Assets Employed	783,334
Retained Profit	25,647		
Dividends	38,470	Bank Loan	85,000
			698,334
(1) Net of depreciation			
(2) Shareholders		Share Capital (2)	25,000
Rupert Johnson	10,000	Retained Profits	673,334
Alison Johnson	5,000		698,334
Mary Johnson	1,000		
Other family members	9,000		

Permission to reproduce items where third-party owned material protected by copyright is included has been sought and cleared where possible. Every reasonable effort has been made by the publisher (OCR) to trace copyright holders, but if any items requiring clearance have unwittingly been included, the publisher will be pleased to make amends at the earliest possible opportunity.

OCR is part of the Cambridge Assessment Group. Cambridge Assessment is the brand name of University of Cambridge Local Examinations Syndicate (UCLES), which is itself a department of the University of Cambridge.